



July 2006

Page 1 of 3

### New High Torque Models



## EZ-Slider

### Sliding Torque Arms

An ideal ergonomic solution for multi-tool applications such as a moving production and assembly line where balancers are fixed to a trolley system.

Provides the same flexibility and comfort of a balancer.

Arm is crafted with a lightweight durable carbon fiber.

Easy to install and improves operator comfort and productivity.

Requires little space and doesn't disrupt production flow.

Mountable with a standard rail system, aluminum extrusion or existing work station.

Horizontal Linear Guide Bush allows the Slider arm to travel horizontally on a production floor. Multiple Slider arms can be mounted to it.

X & Y axis mobility with the EZ-Slider

Model	Item #	Max Torque		Clamp Dia.	Max Vertical Stroke	Max Balancer Capacity	List Price	Code
		lbft.ft	N.m					
EZ-Slider 8	260101	5.9	8	*	17 3/4"	3.3 lbs	\$765.00	C
EZ-Slider 15	260102	11	15	*	17 3/4"	3.3 lbs	\$855.00	C
EZ-Slider 40	260129	29.5	40	1 - 2"	16 1/2"	17.6 lbs	\$2,378.00	C
EZ-Slider 80	260130	59	80	1 - 2"	16 1/2"	22 lbs	\$3,779.00	C

Note: \* The EZ-Slider 8 & 15 comes with a standard 3/8" air fitting. An Electric tool clamp is sold separately

# Product



## Bulletin

July 2006

Page 2 of 3



EZ-Slider 8 & 15

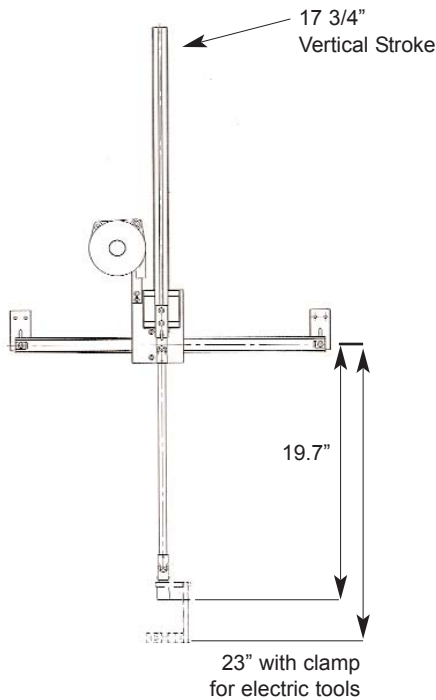

EZ-Slider 40

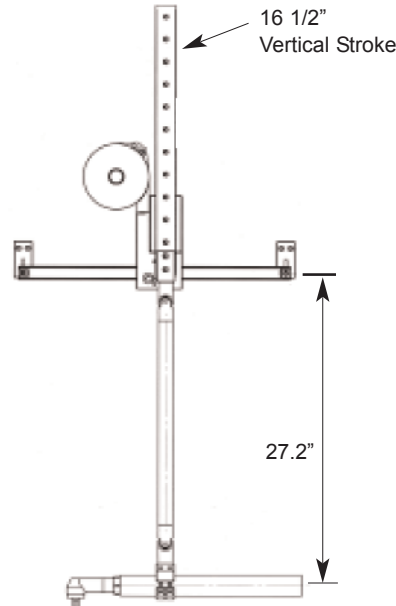

EZ-Slider 80

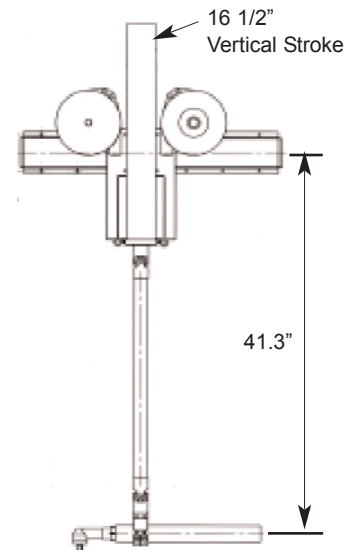

## Accessories

### Horizontal Linear Guide Bush

Allows the Slider arm the freedom to travel horizontally (side to side) on a production floor. The Horizontal Linear Guide Bush connects to a standard rail system, aluminum extrusion or existing overhead system and is available in a variety of lengths. The EZ-Slider mounts onto the "Carriage." Each Horizontal Linear Guide Bush includes one Carriage. Additional Carriages can be purchased separately. Multiple Carriages can be added to the Horizontal Linear Guide Bush, which allows for multiple Slider arms to be used freely on a rail system.



#### For EZ-Slider 8, 15, 40 models

Working Distance	Item #	List Price	Code
450mm	260103	\$295.00	C
650mm	260104	\$345.00	C
850mm	260105	\$360.00	C
1050mm	260106	\$405.00	C
1350mm	260107	\$500.00	C
1850mm	260108	\$590.00	C

#### For EZ-Slider 80 models

Working Distance	Item #	List Price	Code
420mm	260131	\$620.00	C
820mm	260132	\$740.00	C
1320mm	260133	\$905.00	C
1820mm	260134	\$1,105.00	C

v 1.2



### Accessories



#### Carriage

For adding multiple arms to the Horizontal Linear Guide Bush.

**Item # 260109**

**List Price: \$135.00**

**Code: C**



#### Balancer Carriage

Features a hook for mounting a balancer. It can be mounted to the Horizontal Linear Guide Bush.

**Item # 260042**

**List Price: \$150.00**

**Code: C**



#### Thrust Stopper

When having multiple carriages mounted to the Horizontal Linear Guide Bush, it's recommended to place a Thrust Stopper between each carriage.

**Item #260044**

**List Price: \$35.00**

**Code: C**



#### Tool Clamps

Note: \*The EZ-Slider 8 & 12 come with pneumatic 3/8" fitting for air tools. For attaching an electric driver order the following clamp.

Model	Item #	Clamp Dia.	List Price	Code
EZ-Slider 8	260110	1 - 2 "	\$205.00	C
EZ-Slider 15	260111	1 - 2 "	\$220.00	C